

SUGGESTED PRINTED CIRCUIT BOARD MOUNTING DIMENSIONS

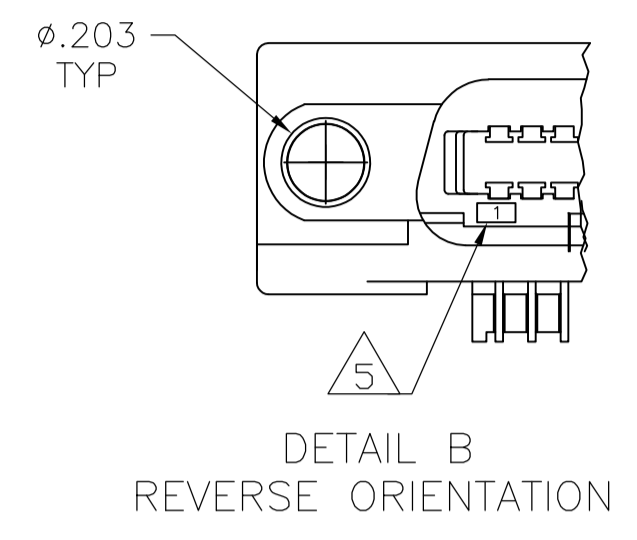

DETAIL B  
REVERSE ORIENTATION

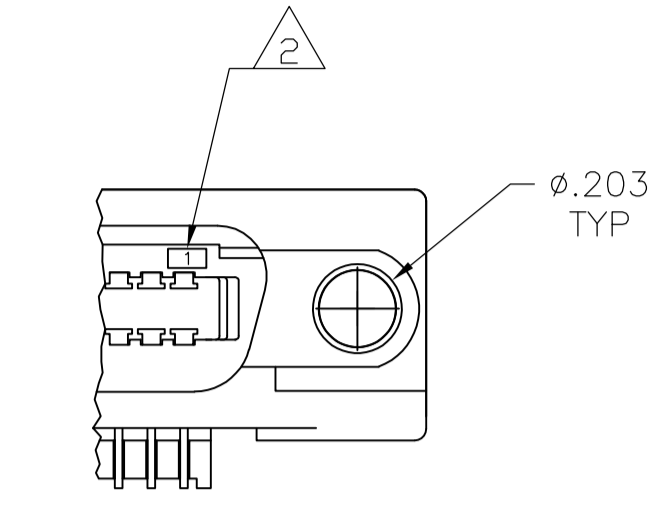

DETAIL A  
STANDARD ORIENTATION

- 1 MATERIAL:  
HOUSING, RIGHT ANGLE BRACKET, ADAPTER COMB & SUPPORT PLATE - THERMOPLASTIC, BLACK.  
TERMINALS - HIGH STRENGTH COPPER ALLOY PLATED WITH EITHER .000030 MIN GOLD PLATE OR GOLD FLASH OVER PALLADIUM NICKEL PLATE, .000030 MIN TOTAL ON MATING SURFACE. .000120 MIN TIN PLATE ON TAILS. ALL OVER .000050 MIN NICKEL UNDERPLATE OVER ENTIRE TERMINAL.
- 2 TERMINAL 1 IS LOCATED IN THIS ROW FOR STANDARD ORIENTATION, SEE DETAIL A.
- 3 PANEL THICKNESS RANGE: .125 MAX.
- 4 SUPPORT PLATE CLEARANCE FOR TERMINAL STRAIN RELIEF AND FLUX REMOVAL.
- 5 TERMINAL 1 IS LOCATED IN THIS ROW FOR REVERSE ORIENTATION, SEE DETAIL B.

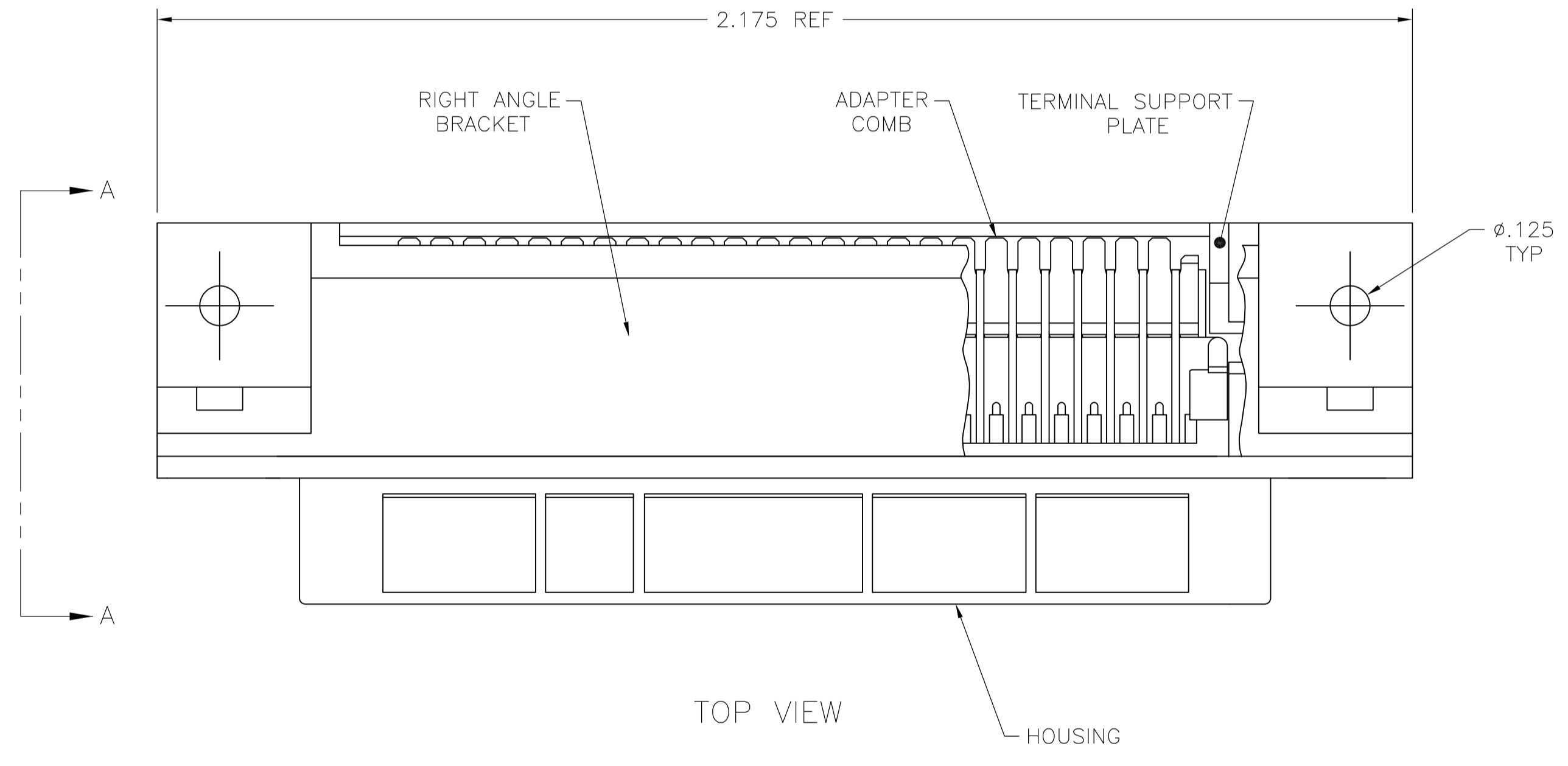

TOP VIEW

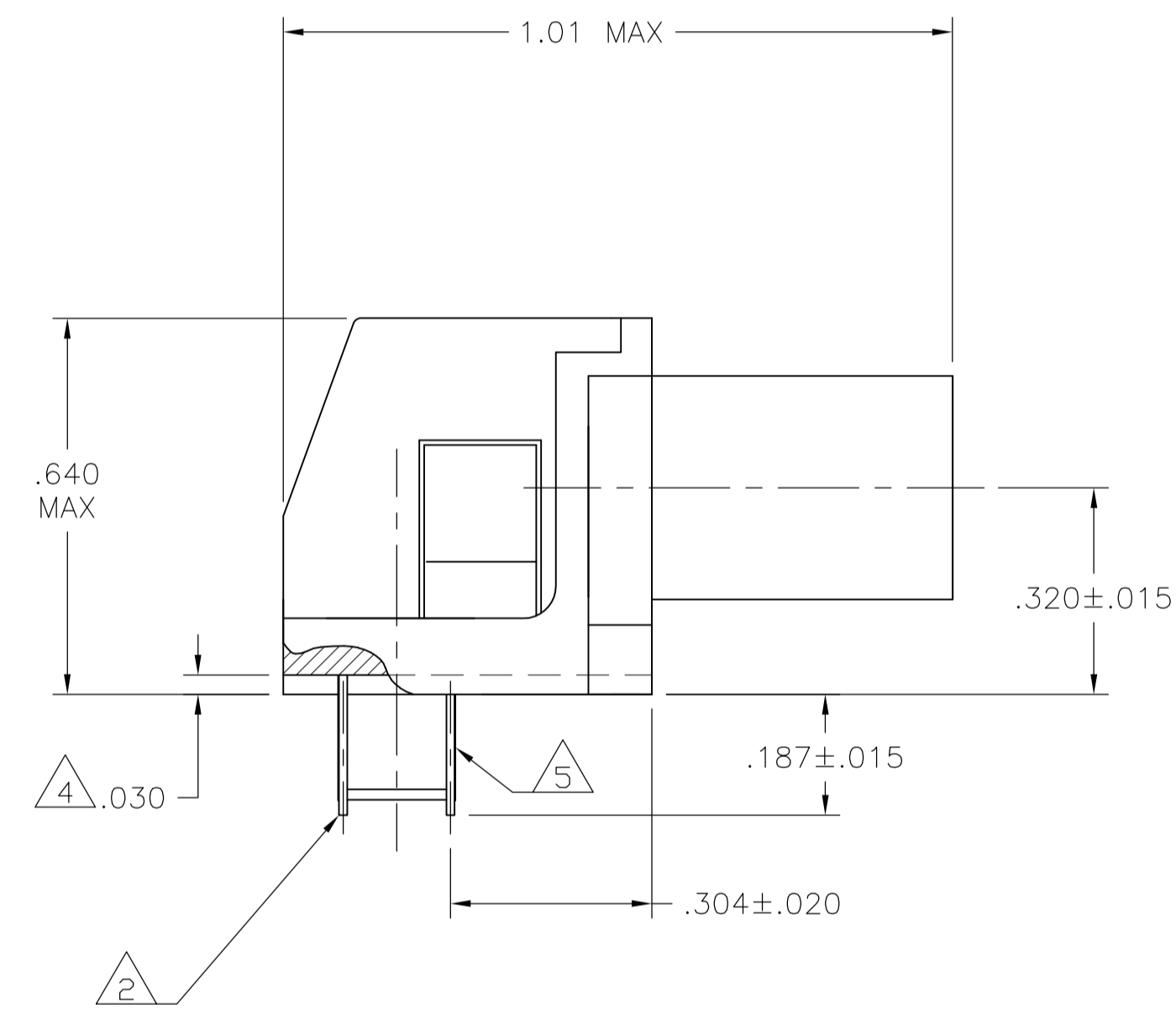

SIDE VIEW A-A

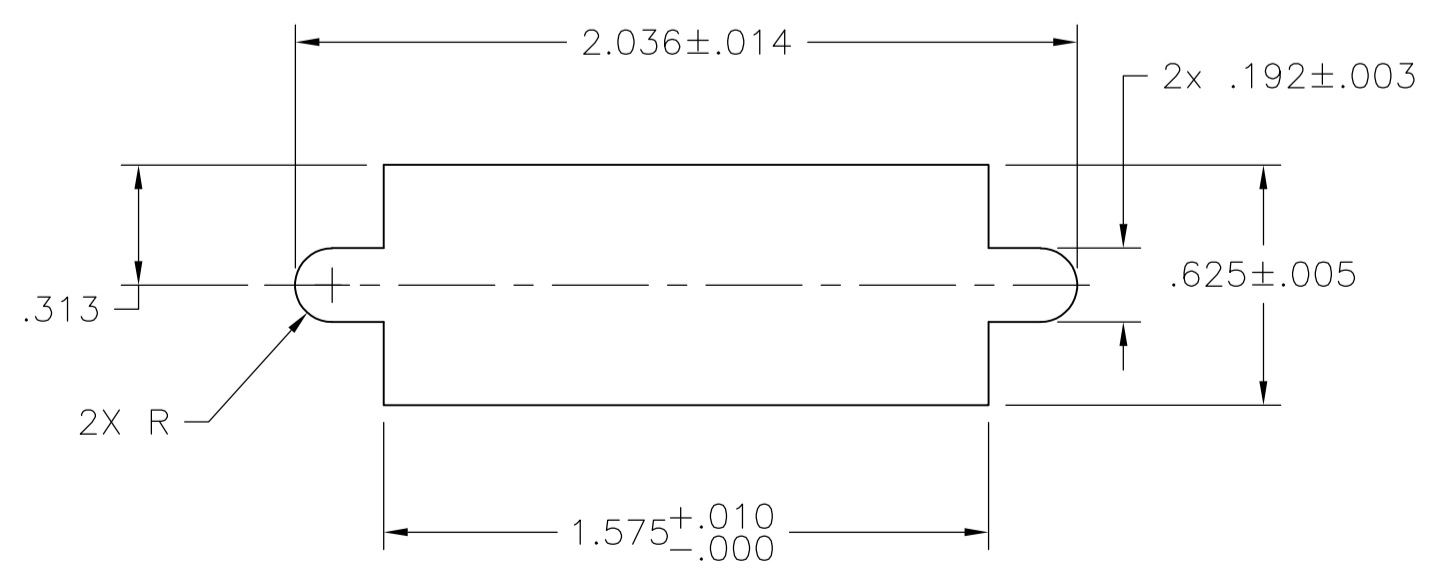

PANEL CUTOUT DIMENSIONS FOR REAR PANEL MOUNTING FOR METRIC HARDWARE

SEE DETAIL B	5553121-2
SEE DETAIL A	5553121-1
DESCRIPTION	PART NUMBER

THIS DRAWING IS A CONTROLLED DOCUMENT.		DIN EJ MCMMASTER 18AUG05	Tyco Electronics Corporation Harrisburg, PA 17105-3608	
DIMENSIONS: INCHES		CHK W MILLHIMES 18AUG05	NAME	
TOLERANCES UNLESS OTHERWISE SPECIFIED:		APP'D M WALMSEY 18AUG05	PRODUCT SPEC	
0 PLC ± -		APPLICATION SPEC		
1 PLC ± -		SIZE		
2 PLC ± -		CAGE CODE		
3 PLC ± .005		DRAWING NO		
4 PLC ± -		WEIGHT		
ANGLES ± -		A1 00779 C=5553121		
FINISH		CUSTOMER DRAWING		
SCALE 2:1		SHEET 1 OF 1		